

SHERPA

Z50 D212



ENG V22.10-1



SHERPA
MINI-LOADERS

TECHNICAL DATA

SHERPA Z50 D212

Motor

Manufacturer	Kubota
Type	D902
Capacity	18/25 KW/Hp
Revolutions per minute	3600 rpm
Adjusted amount of revolutions	3000 rpm
Number of cylinders	3
Cooling	Water cooled (coolant)
Fuel	Diesel
Fuel tank capacity	15 l

Drive system

Hydrostatic through 4 hydraulic wheel motors

Speed

0-8 (proportional) km/h*

Capacity data

Breakout force	726 kg
Tractive force	515 kg*
Hydraulic drive- and working system	42/190 l/bar
Hydraulic tank capacity	42 l

Tires

Standard 20x11.00-8 - Trac profile tires

Brakes

Braking system Hydrostatic through 4 hydraulic wheel motors

Steering

Skid steering

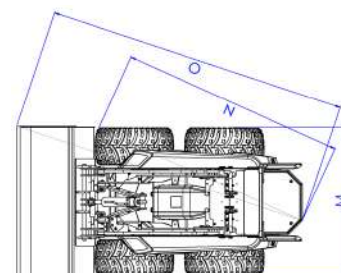
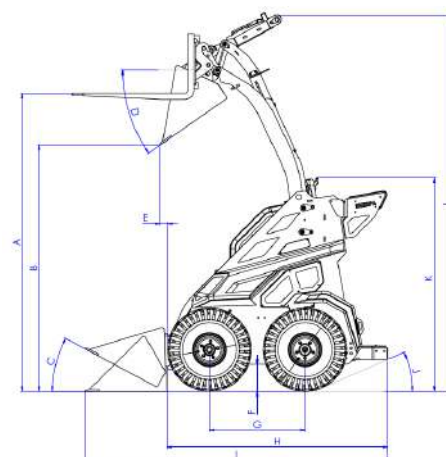

Dimensions in mm on standard tyres

A Max. height pallet forks	2051	J Rear angle	23,5°
B Max. dump height	1700	K Height machine	1495
C Angle bucket low	28°	L Total max height	2590
D Bucket angle when dumping	35°	M Width narrow tires	860
E Length from front wheel to bucket when dumping	50	N Width wide tires	1140
F Ground clearance	188	O Turning radius	1664
G Wheelbase	657	O Turning radius with bucket(76cm)	2208
H Length machine (folded footplate)	1519 ⁽¹³⁴⁵⁾		
I Length machine with bucket	2075		

* Depending on choice of tires

specifications and features are subject to change without notice

TECHNICAL DATA

SHERPA Z50 D212

Electrical system

Voltage	12 V
Battery capacity	45 Ah

Max. Dimensions (L mm x B mm x H mm, without bucket)

Standard	1519 x 1140 x 1495
----------	--------------------

Kerb weight

862 kg (with standard tires)

Tipping loads (kg)*

Pallet forks low**

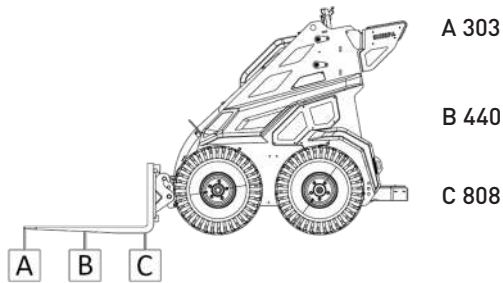

Pallet forks high**

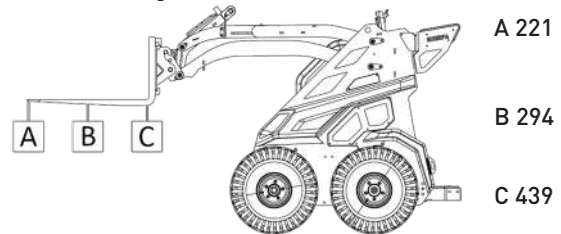

* Including driver 75kg

** Consider a safety factor of 30%

SHERPA Z50 D212

The unquestionable powerhouse of the SHERPA Z-series – the Z50 will successfully take on any challenge! This machine is 114 centimetres wide and equipped with a reliable 25 hp Kubota D902 diesel engine. That makes this machine the most powerful skidsteer in our line up.

More information?

Call us +31 412 61 33 44

Canadabaan 14 | 5388 RT Nistelrode | www.sherpaminiloaders.com

